

4-WIRE BUS VIDEO APARTMENT INTERCOM SYSTEM

GFW-VBC, Video expander control unit

INSTALLATION MANUAL

 **GFW-VBC is compatible with GF-VBC/A unit only (not GF-VBC).**

FEATURES

The GFW-VBC is designed to enlarge video capacity of GF apartment system in combination with GF-VBC/A and one more GFW-VBC:

Purpose	Standard & expanded capacity
1. To increase total monitor stations	Total 150 units GF-1MD(K) expandable to 151~250 units
2. To maximize wiring distance	Max. 150m. Doubled to 300m with one GFW-VBC, tripled to 450m with two GFW-VBC's
3. To increase Video trunk lines	One video trunk line can be divided into 6 trunk lines, totaling max. 216 video trunk lines.

Note; Up to two GFW-VBC's (in series) can be installed per system.

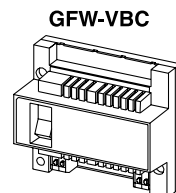





GFW-VBC







- Package contents**
- GFW-VBC
 - INSTALLATION MANUAL

PRECAUTIONS General Prohibitions Prohibitions to subject the unit to water Prohibitions to dismantle the unit

WARNING (Negligence could result in death or serious injury to people)

1. This device is electrical. Wiring must be done by qualified personnel. 
2. Do not dismantle or alter the unit. Fire or electric shock could result. 
3. Do not connect any power source other than specified to terminals +, = on the unit. Fire or electric shock could result. 
4. Keep the unit away from water or any other liquid. Fire or electric shock could result. 
5. Make sure wires are connected properly before plugging the power supply into an electrical outlet. 
6. For DC powered systems, use Aiphone power supply model specified with system. If non-specified product is used, fire or malfunction could result.

CAUTION (Negligence could result in injury to people or damage to property)

1. Do not install or make any wire terminations while power supply is turned on. Unit trouble could result. 
2. Mount the unit on wall in a convenient location, but not where it could be bumped or jarred. Injury could result. 
3. Do not install the unit in any of the following locations, as it may cause the system to malfunction:
 - **High or extreme cold temperature area:** under direct sunlight, near equipment that varies in temperature, in front of air-conditioner, inside a refrigerated area, etc. 
 - **Places subject to moisture or humidity extremes,** such as bathroom, cellar, greenhouse, etc. 
 - **Places subject to environmental conditions,** such as dust, oil, chemicals, salt, etc. 
 - **Places subject to constant vibration or impact.** 
 - **Places subject to steam or smoke,** such as near heating appliances, cooking surface, etc. 

GENERAL PRECAUTIONS

1. The equipment, except the entrance station, is designed for indoor use only. Do not install them outdoors.
2. The system is not operable during a power failure.
3. Keep all wiring at least 30cm, 1' away from AC100 ~ 240V wiring, fluorescent lighting, or dimmer switches. Otherwise, cross AC wiring at a 90° angle.

MOUNTING

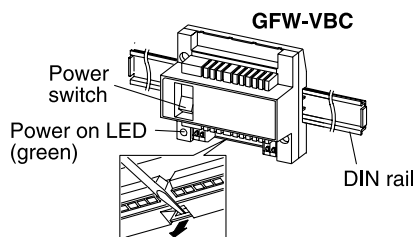
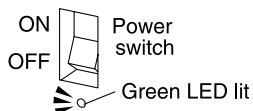
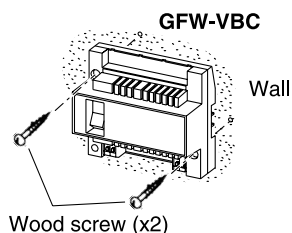

Mounting rail for GFW-VBC: W-DIN11 available from Aiphone

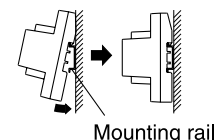

When green LED is not lit, turn off the Power switch on GFW-VBC, and check on wiring and fuse inside the power supply.

SYSTEM CONFIGURATION

1 Example to maximize wiring distance

8 residences per floor, 30 floors; total 250 residences

- Distance calculation: From GF-VBC/A or GFW-VBC to the farthest monitor station; Max. 150m w/ ϕ 0.8mm (500' w/20AWG) per video trunk line.

A + **B** 51m + 80m = 131m
 170' + 260' = 430'
C + **D** 39m + 80m = 119m
 128' + 260' = 388'

CAUTION
 Do not mix both wiring methods: monitor-to monitor and homerun to GF-4Z's for any residential trunk line.

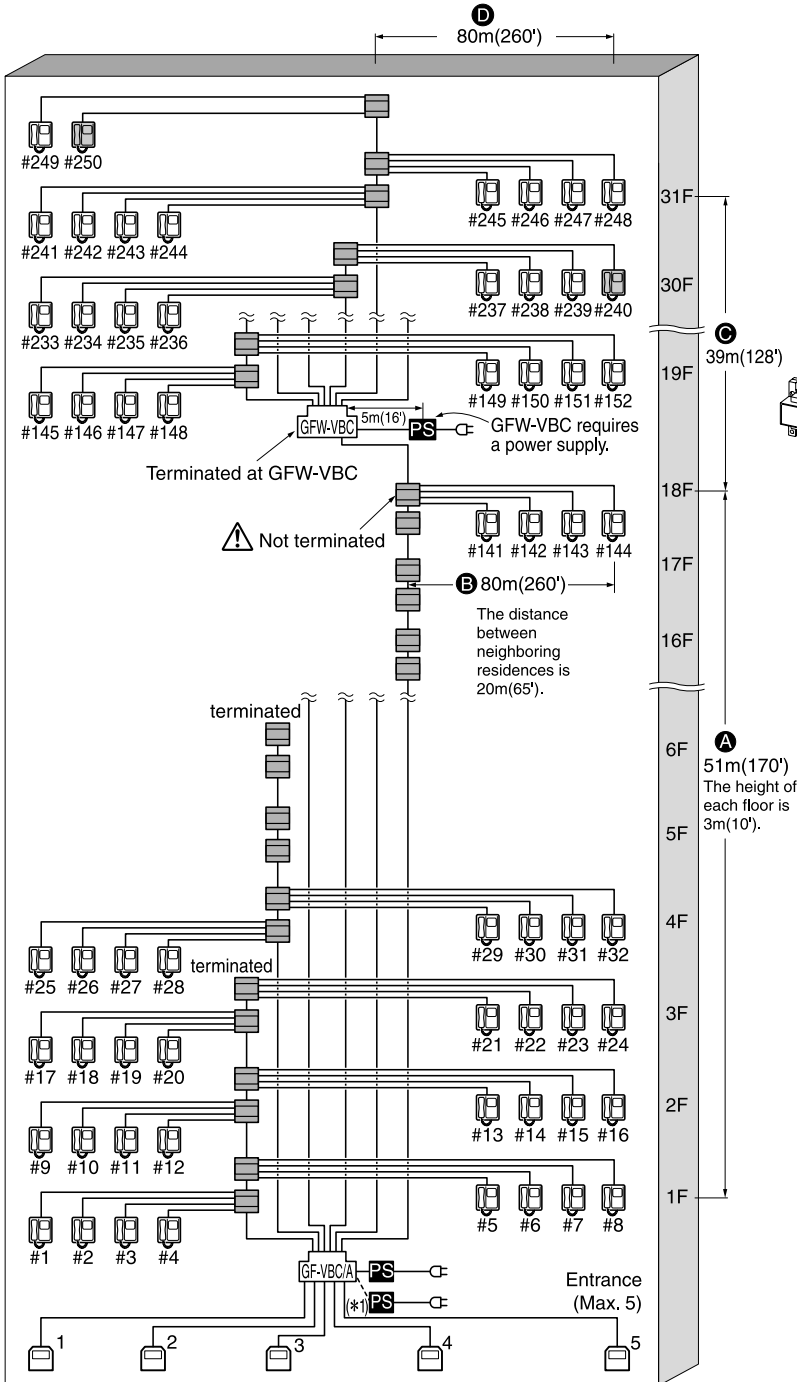
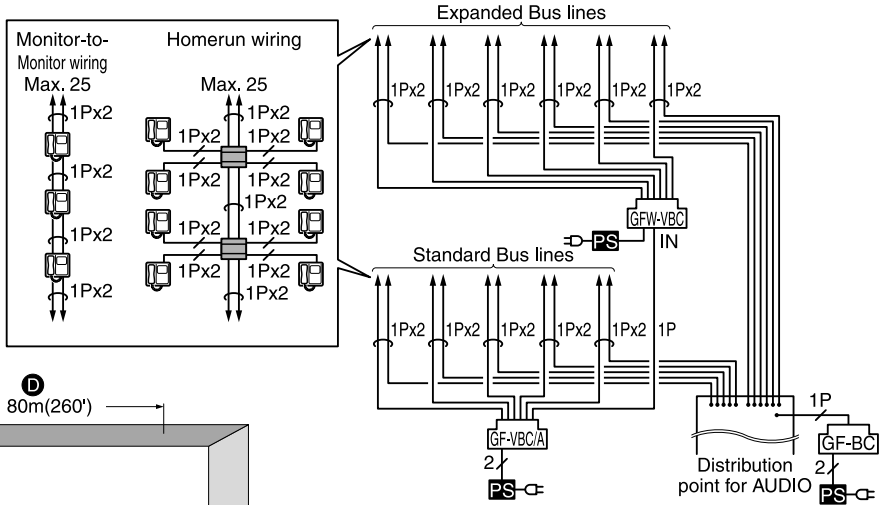

When GFW-VBC further extends trunk line;
 On the GF-4Z, the GFW-VBC is connected to, put SW1 to B position (not terminated).

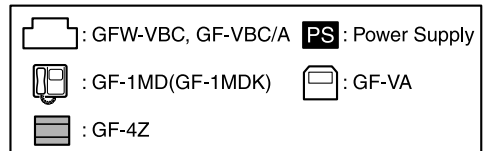
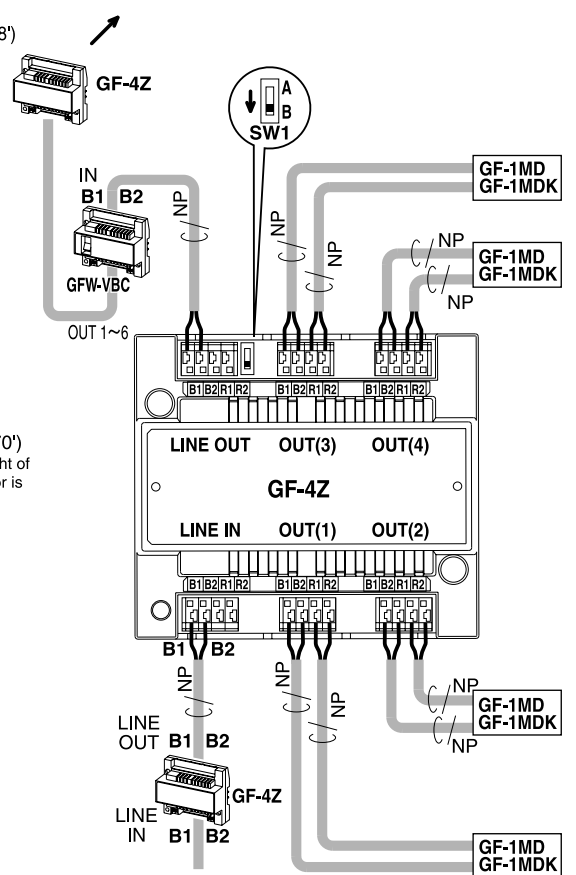

Audio wiring is not shown.

(*1): Install an add-on power supply when 2nd GF-1MD is installed in each apartment.

2 Example to increase video trunk lines

4 residences per floor, 12 floors (total 48 residences), 5 blocks; total 240 residences

- Distance calculation : From GF-VBC/A or GFW-VBC to the farthest apartment stations; Max. 150m w/ ϕ 0.8mm (500' w/20AWG) per video trunk line.

$$\textcircled{A} + \textcircled{B} + \textcircled{C} \quad 80\text{m} + 33\text{m} + 30\text{m} = 143\text{m}$$

$$260' + 108' + 100' = 468'$$

CAUTION

Do not mix both wiring methods: monitor-to-monitor and homerun to GF-4Z's for any residential trunk line.

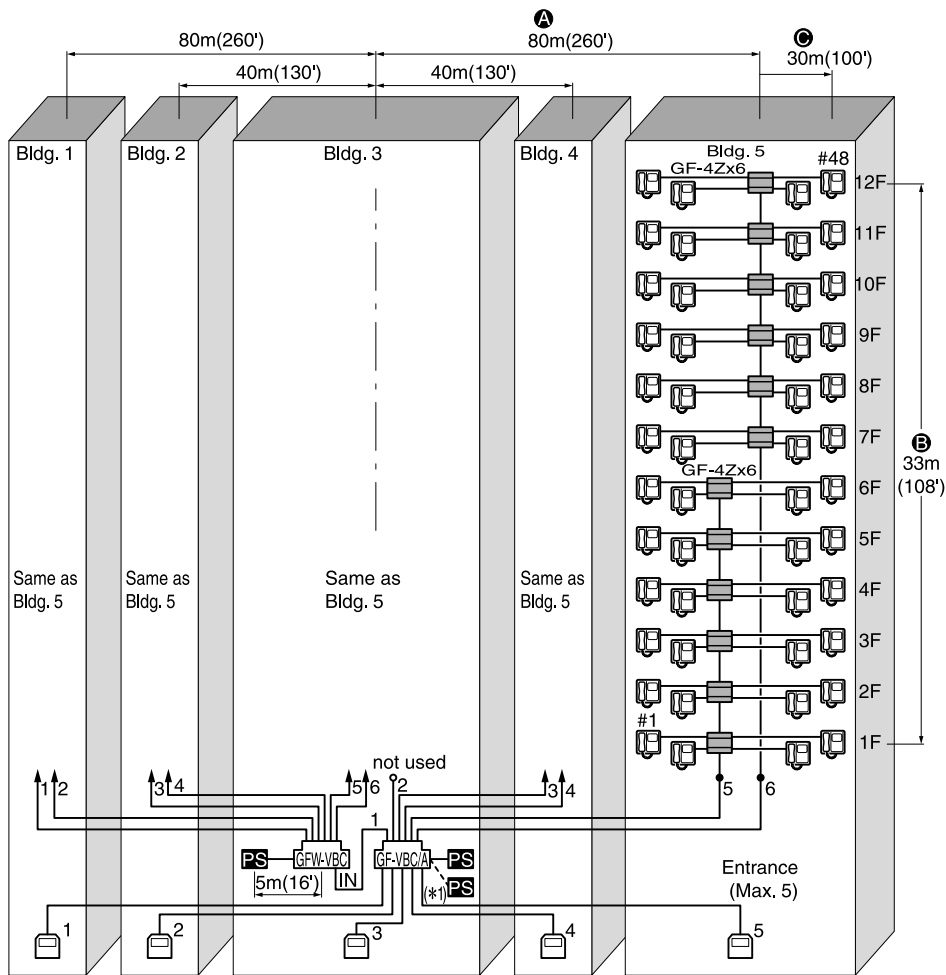
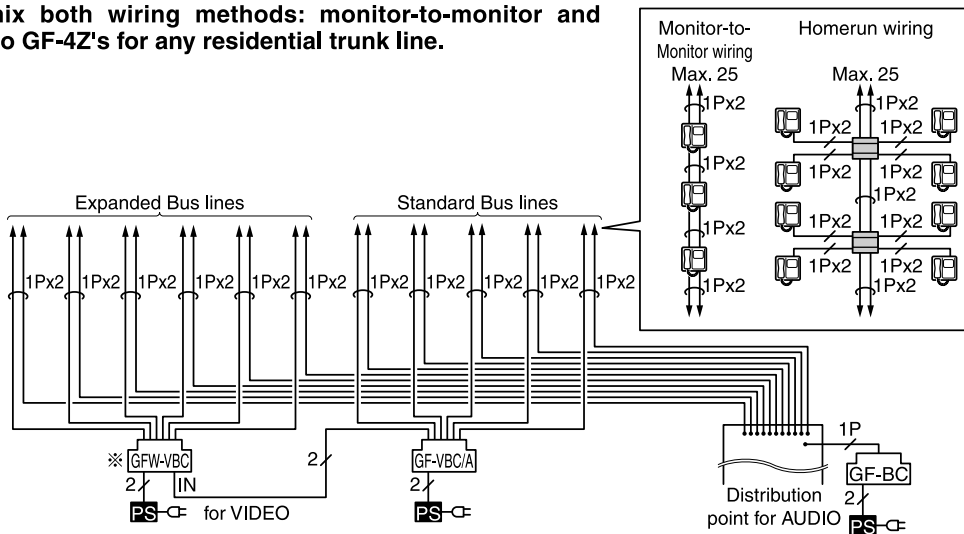
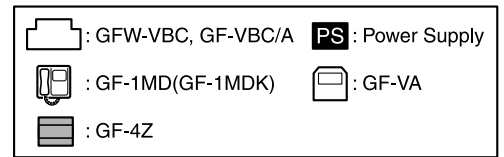

Audio wiring is not shown.

(*1): Install an add-on power supply when 2nd GF-1MD is installed in each apartment.

WIRING

⚠ For entire GF system wiring, refer to GF system's Installation manual.

GFW-VBC Video trunk line wiring
Audio wiring is not shown.

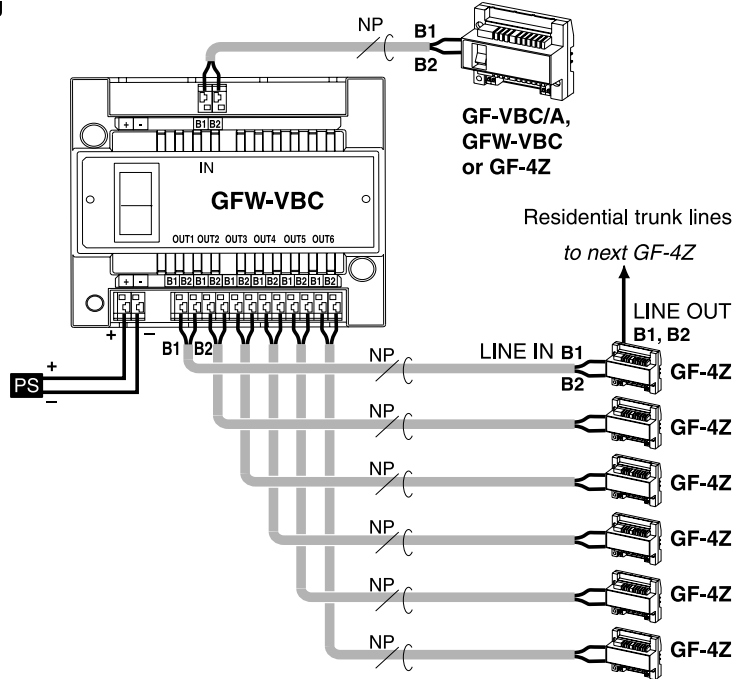

SPECIFICATIONS

- **Power source:** DC 24V, supplied by a power supply PS-2410LC, PS-2410LD or PS-24ME/A.
- **Current consumption:** 0.9A.
- **Wiring:** 2 x 2-wire cables common.
- **Type of Cable:** 2-conductor cable solid copper & non-braided, polyethylene insulation, 0.65mm dia. ~ 1.0mm dia. (22AWG ~ 18AWG).

• **Wiring distance:**

Diameter of wires	0.65mm	0.8mm	1.0mm	22AWG	20AWG	18AWG
GFW-VBC to farthest GF-1MD 1 per resid. line	100m	150m	—	330'	500'	—
GFW-VBC to GF-VBC/A						
GFW-VBC to farthest GF-1MD 2 per resid. line	50m	100m	150m	165'	330'	500'
GFW-VBC to GF-VBC/A						
GFW-VBC to power supply	—	5m	—	—	16'	—

• **Capacity:**

	Standard system	Expanded system
• Video control unit	1 x GF-VBC/A	1 x GF-VBC/A 2 x GFW-VBC
• Total monitor station	150 x GF-1MD (or GF-1MDK)	250 x GF-1MD (or GF-1MDK)

• **Dimensions & weight:**

108.5mm(H) x 122.5mm(W) x 61mm(D) 260g approx.
4-1/4"(H) x 4-13/16"(W) x 2-3/8"(D) 0.57 lbs. approx.

This equipment has been tested and found to comply with the limits for a Class B digital device, pursuant to Part 15 of the FCC Rules. These limits are designed to provide reasonable protection against harmful interference in a residential installation. This equipment generates, uses, and can radiate radio frequency energy and, if not installed and used in accordance with the instructions, may cause harmful interference to radio communications. However, there is no guarantee that interference will not occur in a particular installation. If this equipment does cause harmful interference to radio or television reception, which can be determined by turning the equipment off and on, the user is encouraged to try to correct the interference by one or more of the following measures:

- Reorient or relocate the receiving antenna.
- Connect the equipment into an outlet on a circuit different from that to which the receiver is connected.
- Increase the separation between the equipment and receiver.
- Consult the dealer or an experienced radio/TV technician for help.

WARRANTY

Aiphone warrants its products to be free from defects of material and workmanship under normal use and service for a period of one year after delivery to the ultimate user and will repair free of charge or replace at no charge, should it become defective upon which examination shall disclose to be defective and under warranty. Aiphone reserves unto itself the sole right to make the final decision whether there is a defect in materials and/or workmanship; and whether or not the product is within the warranty.

This warranty shall not apply to any Aiphone product which has been subject to misuse, neglect, accident, or to use in violation of instructions furnished, nor extended to units which have been repaired or altered outside of the factory.

This warranty does not cover batteries or damage caused by batteries used in connection with the unit.

This warranty covers bench repairs only, and any repairs must be made at the shop or place designated in writing by Aiphone.

Aiphone will not be responsible for any costs incurred involving on site service calls.

AIPHONE CO., LTD., NAGOYA, JAPAN
AIPHONE CORPORATION, BELLEVUE, WA, USA
AIPHONE EUROPE N.V., ANTWERP, BELGIUM

AIPHONE[®]
Providing Peace of Mind
<http://www.aiphone.com/>
Printed in Thailand (E)